

**3/S1**  
v 3.3 (en)

## JET NOZZLES

SAP-F, SAP-Z



**TABLE OF CONTENTS**

Jet nozzles SAP-Z.....	193
Jet nozzles SAP-F.....	194
Selection diagrams.....	196
Motor drive.....	202

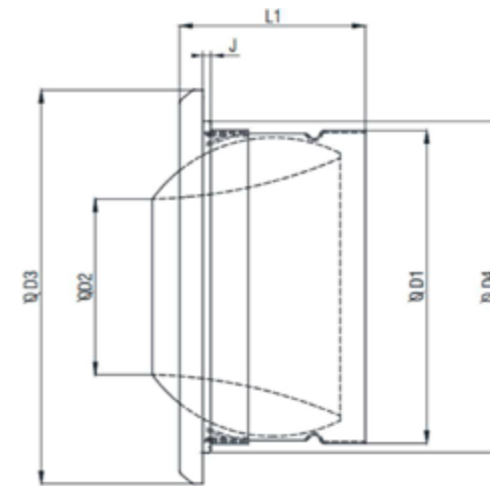

**SAP - Z**

- For air supply with large throw distance and low noise requirements
- Made of anodized aluminium, standard powder coating in RAL 9010.
- Adjustable discharge angle ( $\pm 30^\circ$ )

**Options**

- RAL...
- Motor drive

Dimensions	Ø D1	Ø D2	Ø D3	L1	Ø D4	J
100	98,6	55,7	147	79	94,7	2
125	121	60	171	89	131	0
160	157,6	81	212	118	171,2	5
200	199	102,1	255,5	138	217,4	5
250	247	131,1	302	178	261,5	8
315	313,6	182,2	381	195	323	10
400	397,1	229	364,7	214	406,3	10

Fast selection table SAP-Z

	ØD2	V (m³/h)	v <sub>ef</sub> (m/s)	L (m)	L <sub>WA</sub> (dB(A))	v <sub>L</sub> (m/s)	V (m³/h)	v <sub>ef</sub> (m/s)	L (m)	L <sub>WA</sub> (dB(A))	v <sub>L</sub> (m/s)	V (m³/h)	v <sub>ef</sub> (m/s)	L (m)	L <sub>WA</sub> (dB(A))	v <sub>L</sub> (m/s)
100	50	47	6,62	10 m	<20	0,25 m/s	94	13,24	20 m	31	0,25 m/s	140	19,86	30 m	42	0,25 m/s
125	64	61	5,28		<20		122	10,57		27		180	15,54		37	
160	82	83	4,36		<20		166	8,71		<20		248	13,07		32	
200	108	104	3,17		<20		220	6,66		<20		306	9,28		25	
250	136	133	2,55		<20		274	5,23		<20		382	7,30		23	
315	174	180	2,10		<20		353	4,12		<20		540	6,31		21	
400	230	234	1,56		<20		464	3,10		<20		702	4,69		<20	

	ØD2	V (m³/h)	v <sub>ef</sub> (m/s)	L (m)	L <sub>WA</sub> (dB(A))	v <sub>L</sub> (m/s)	V (m³/h)	v <sub>ef</sub> (m/s)	L (m)	L <sub>WA</sub> (dB(A))	v <sub>L</sub> (m/s)	V (m³/h)	v <sub>ef</sub> (m/s)	L (m)	L <sub>WA</sub> (dB(A))	v <sub>L</sub> (m/s)
100	50	94	13,24	10 m	31	0,5 m/s	187	26,48	20 m	51	0,5 m/s	187	26,48	30 m	51	0,5 m/s
125	64	122	10,57		27		245	21,14		46		306	26,42		51	
160	82	166	8,71		<20		331	17,42		39		497	26,13		50	
200	108	220	6,66		<20		436	13,21		36		655	19,87		47	
250	136	274	5,23		<20		547	10,46		32		824	15,76		43	
315	174	353	4,12		<20		702	8,20		27		1055	12,32		39	
400	230	464	3,10		<20		929	6,21		27		1393	9,31		37	

Definition of symbols:

V [m³/h]	- Airflow rate	H <sub>uk</sub> [m]	- Installation height
y [m]	- Jet deflection	α [°]	- Angle of deflection
A [m]	- Horizontal difference between nozzle and point of jet collision	v <sub>L</sub> [m/s]	- Medium air velocity at a point of jet collision
B [m]	- Distance between two nozzles in row	v <sub>H1</sub> [m/s]	- Average air velocity at occupied zone
L [m]	- Throw distance	Δt <sub>H1</sub> [K]	- Temperature difference between supply air at throw distance and room temperature
L <sub>max</sub> [m/s]	- Total air throw of isothermal vertical jet	Δt <sub>L</sub> [K]	- Difference between core and room temperature
H <sub>1</sub> [m]	- Distance from occupied zone to collision point of two cold jet		
H <sub>2</sub>	- Distance from occupied zone to collision point of two warm jet		



**SAP - F**

- For air supply with large throw distance and low noise requirements
- Made of anodized aluminium, standard powder coating in RAL 9010.

Options

- RAL...

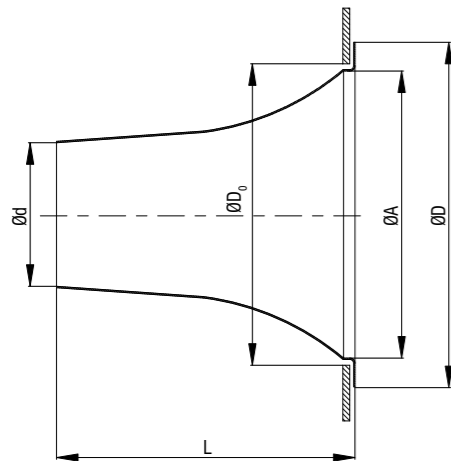

SAP-F	Ød [mm]	ØD [mm]	ØD <sub>0</sub> [mm]	ØA [mm]	L [mm]	A <sub>ef</sub> [m <sup>2</sup> ]
	50	130	105	100	105	0,002
	75	180	156	150	157	0,004
	100	240	210	200	210	0,007
	125	330	295	285	240	0,012
	150	350	310	300	290	0,017
	175	350	310	300	190	0,024
200	510	460	450	380	0,031	

Fast selection table SAP-F

V (m <sup>3</sup> /h)	v <sub>ef</sub> (m/s)	L (m)	L <sub>WA</sub> (dB(A))	v <sub>L</sub> (m/s)	V (m <sup>3</sup> /h)	v <sub>ef</sub> (m/s)	L (m)	L <sub>WA</sub> (dB(A))	v <sub>L</sub> (m/s)	V (m <sup>3</sup> /h)	v <sub>ef</sub> (m/s)	L (m)	L <sub>WA</sub> (dB(A))	v <sub>L</sub> (m/s)
50	47	6,65	<20	0,25	94	13,30	10	31	0,25	140	19,81	20	42	0,25
75	76	4,78	<20	0,25	150	9,43	20	24	0,25	223	14,02	30	35	0,25
100	97	3,43	<20		195	6,90		<20		324	11,46		30	
125	130	2,94	<20	0,5	263	5,95	20	<20	0,5	367	8,31	30	24	0,25
150	137	2,15	<20		288	4,53		<20		430	6,76		22	
175	170	1,96	<20		355	4,10		<20		558	6,44		20	
200	205	1,81	<20	432	3,82	<20	630	5,57	20					

V (m <sup>3</sup> /h)	v <sub>ef</sub> (m/s)	L (m)	L <sub>WA</sub> (dB(A))	v <sub>L</sub> (m/s)	V (m <sup>3</sup> /h)	v <sub>ef</sub> (m/s)	L (m)	L <sub>WA</sub> (dB(A))	v <sub>L</sub> (m/s)	V (m <sup>3</sup> /h)	v <sub>ef</sub> (m/s)	L (m)	L <sub>WA</sub> (dB(A))	v <sub>L</sub> (m/s)
50	94	13,30	31	0,5	187	26,46	10	51	0,5	187	26,46	20	51	0,5
75	155	9,75	25	0,5	306	19,24	20	42	0,5	418	26,28	30	50	0,5
100	225	7,96	<20		432	15,28		<20		612	21,65		49	
125	270	6,11	<20	0,5	486	11,00	20	34	0,5	756	17,11	30	45	0,5
150	295	4,64	<20		594	9,34		<20		900	14,15		42	
175	360	4,16	<20		706	8,15		<20		1062	12,26		39	
200	432	3,82	<20	468	4,14	<20	27	27	1152	10,19	38			

Isothermal air jet

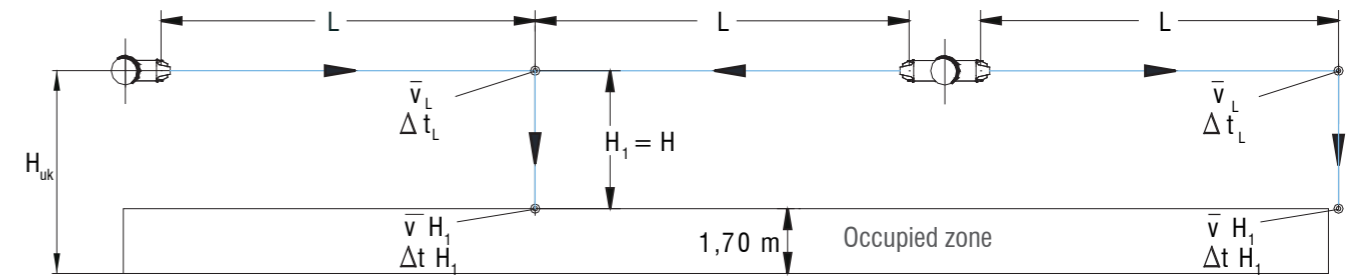

Cold air jet

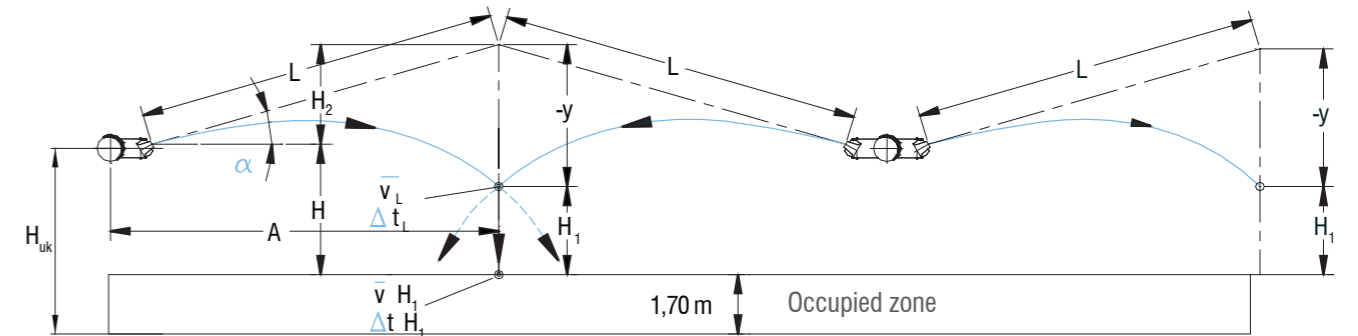

Warm air jet

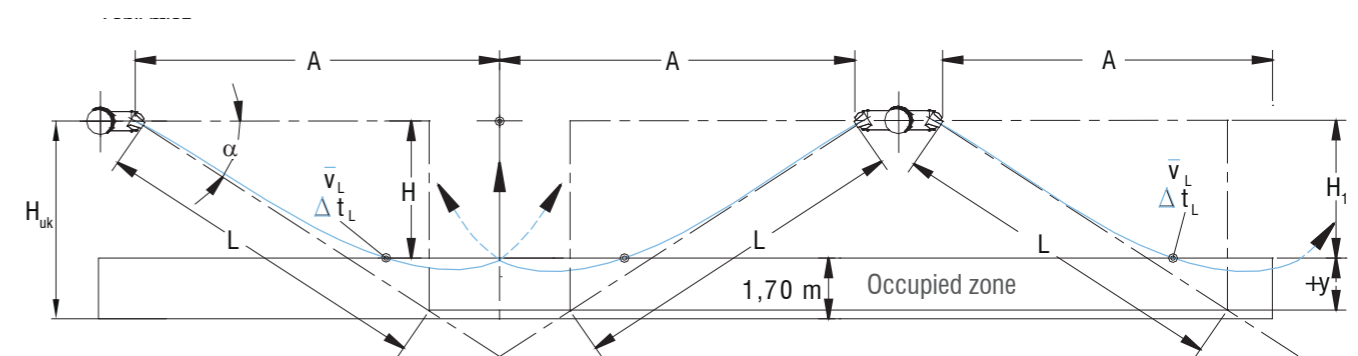

SELECTION DIAGRAMS

Horizontal isothermal air jet SAP-F

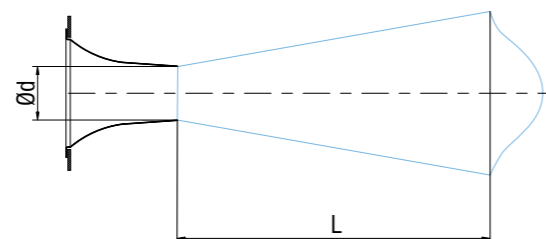
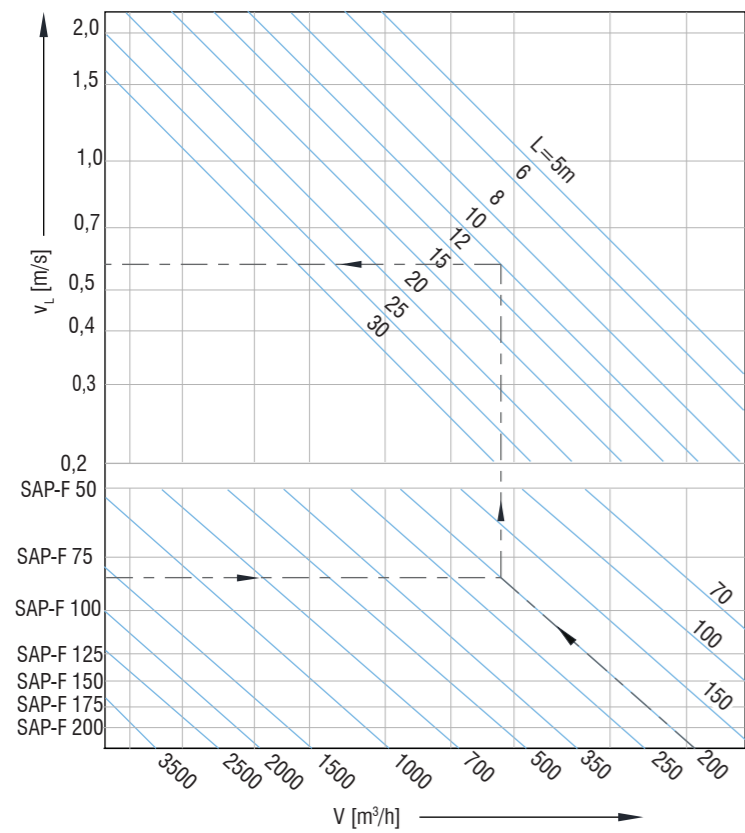

Horizontal isothermal air jet SAP-Z

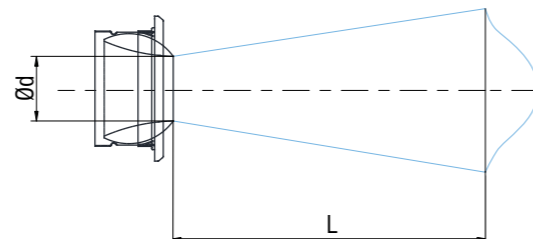
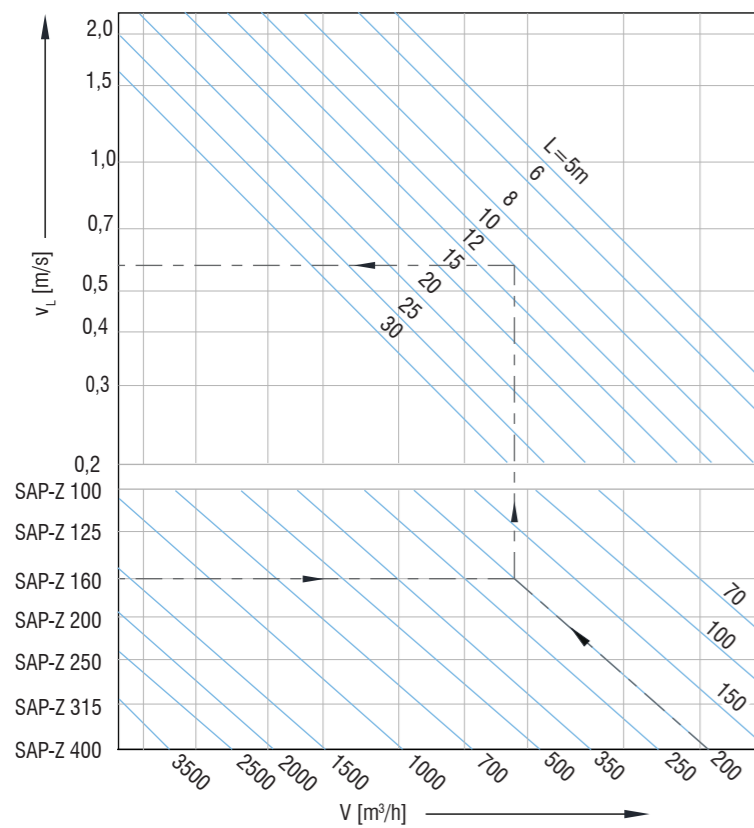

Vertical warm air jet SAP-F

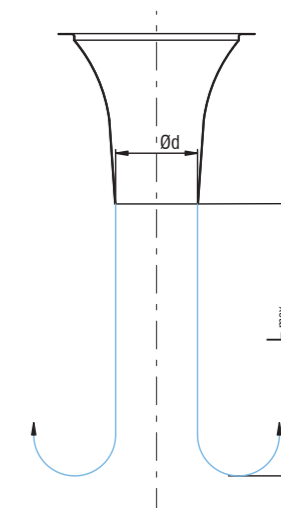
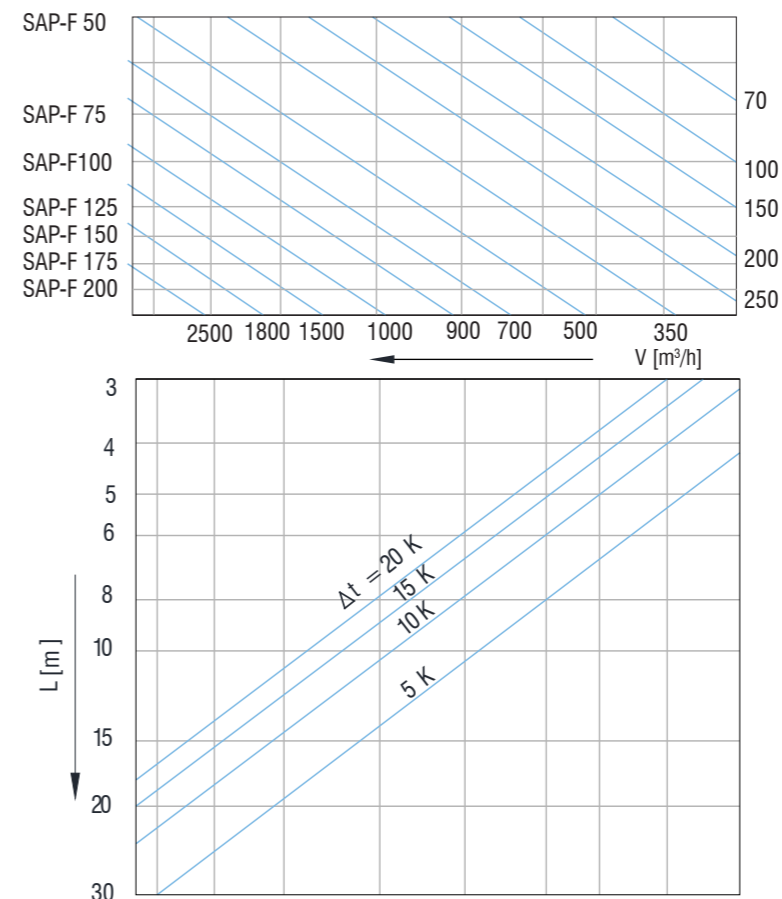

Vertical warm air jet SAP-Z

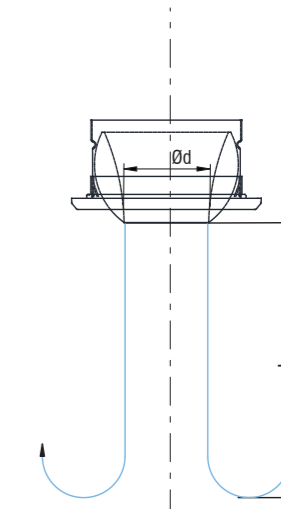
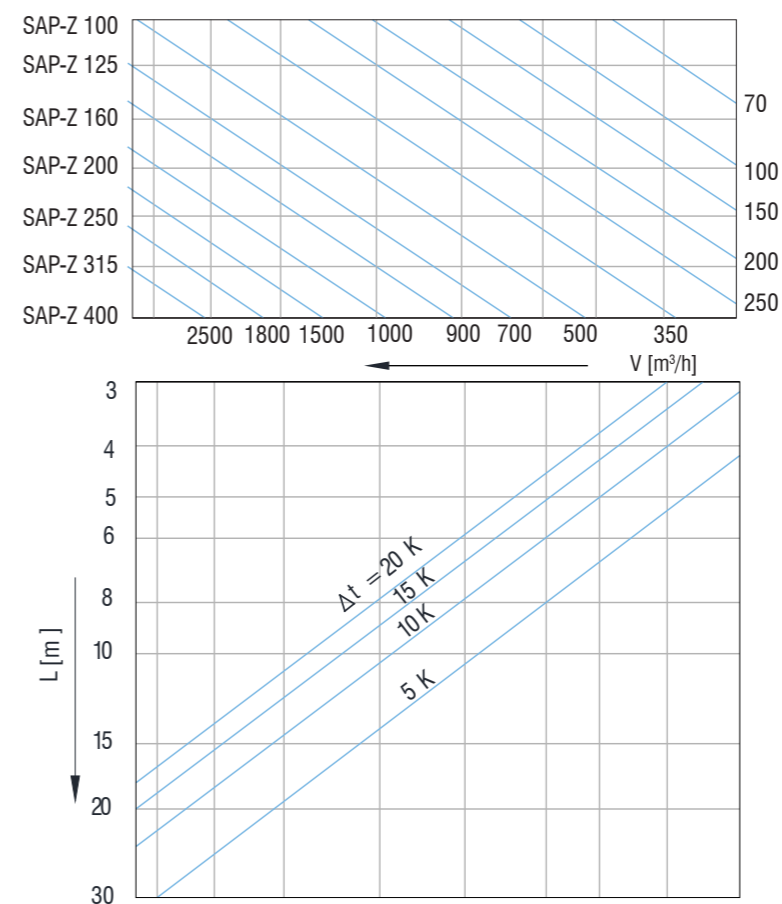

Horizontal non isothermal air jet deflection SAP-F

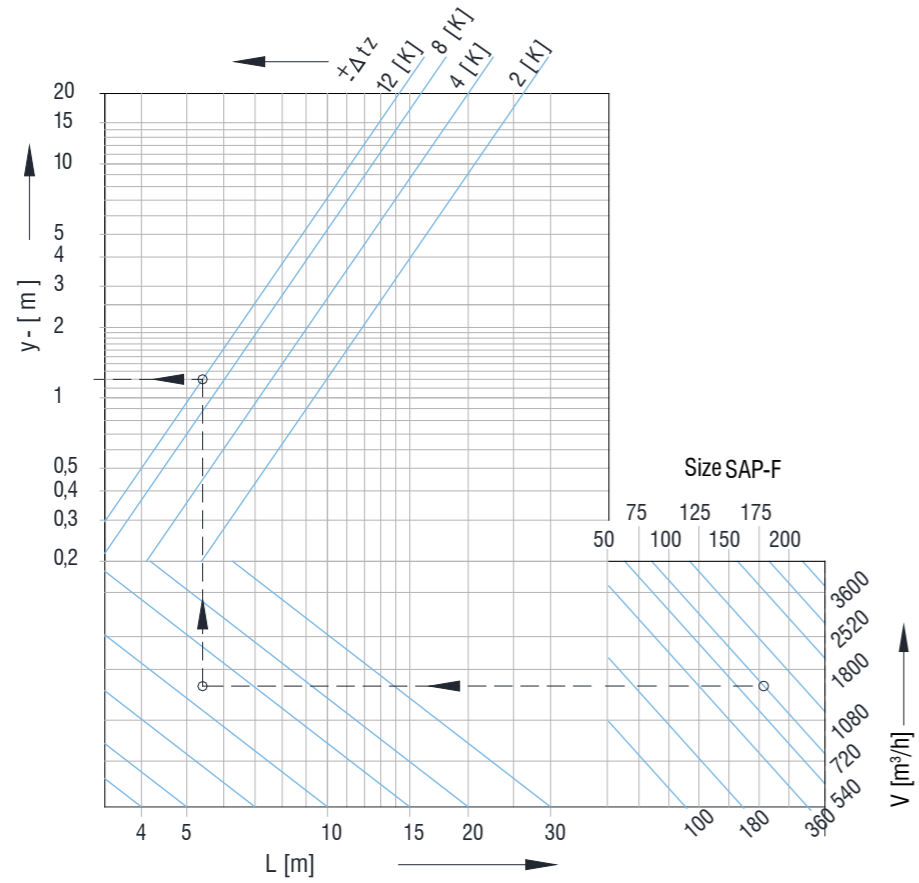

Horizontal non isothermal air jet deflection SAP-Z

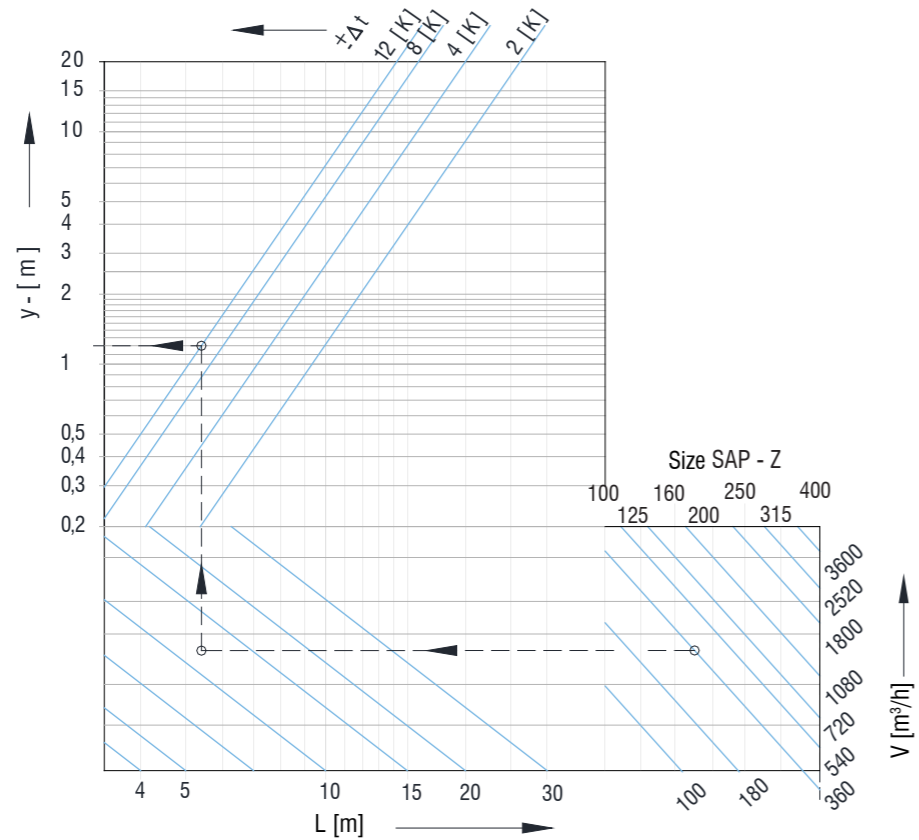

Axial installation SAP-F

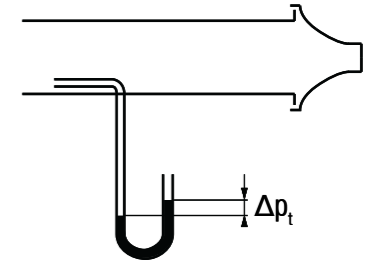
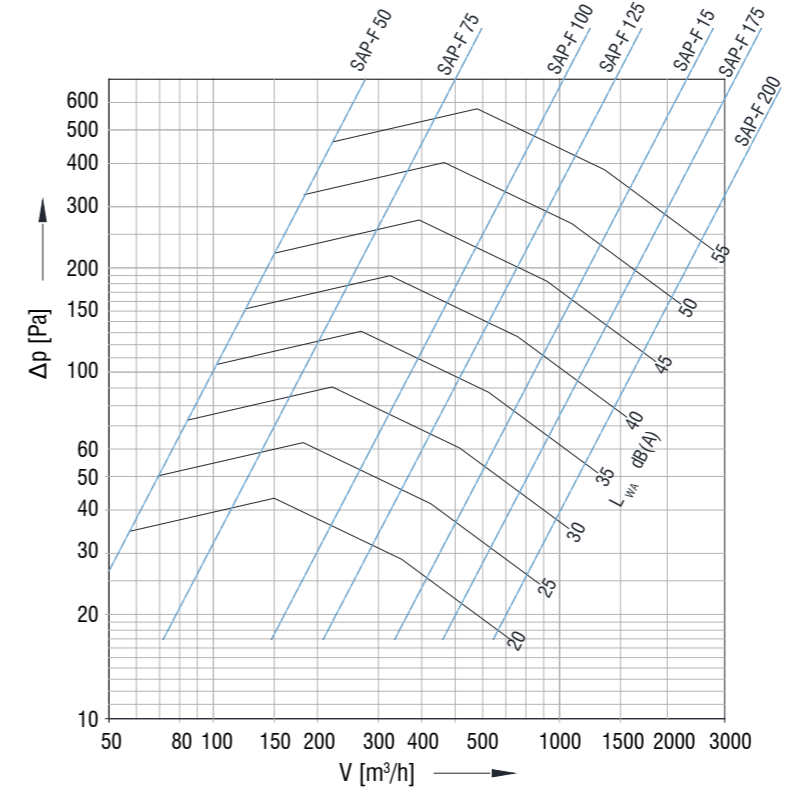

Axial installation SAP-Z

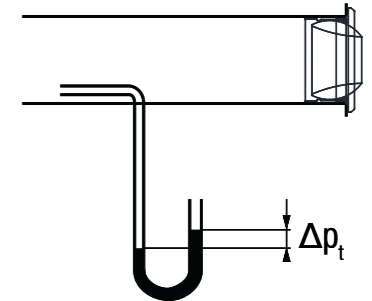
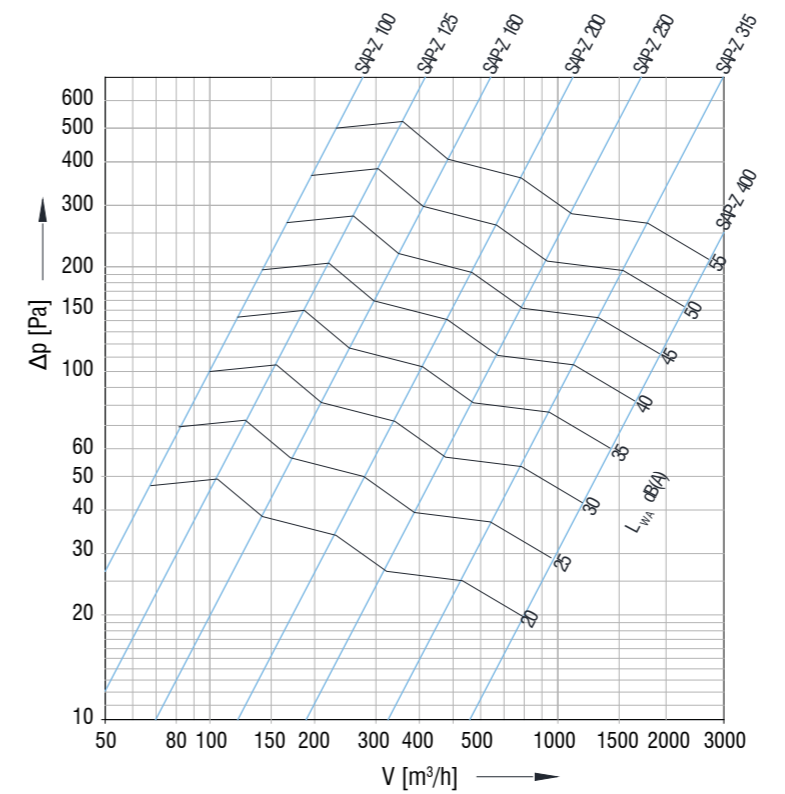

Multiple duct installation SAP-F

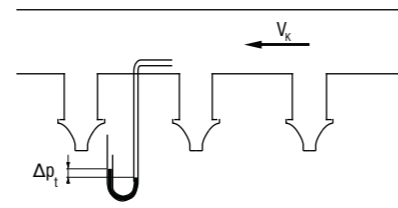
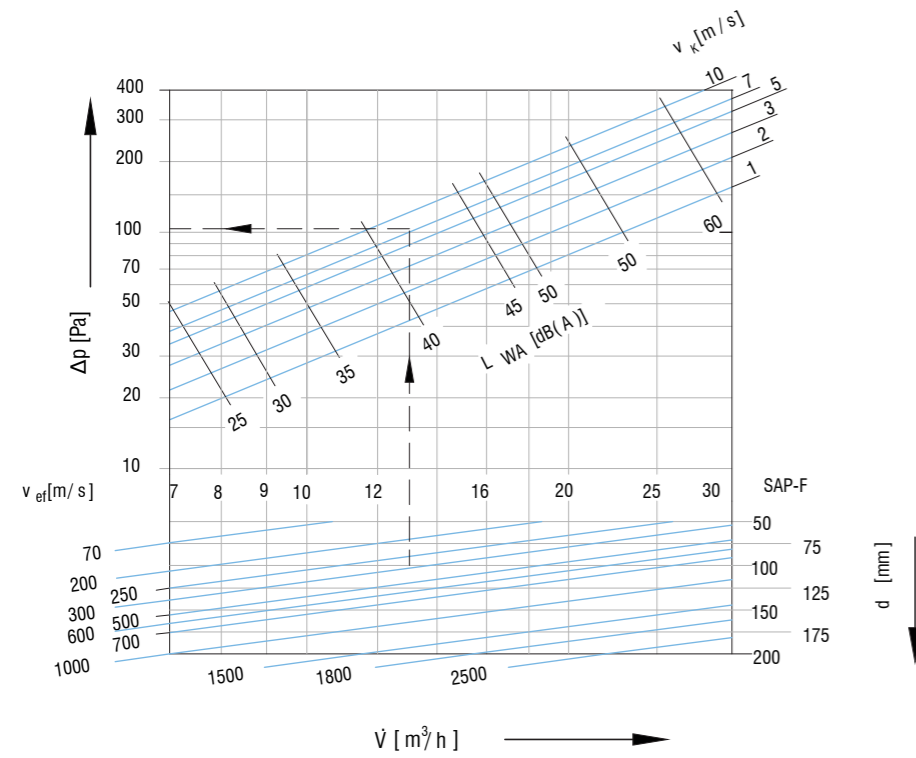

Core velocity

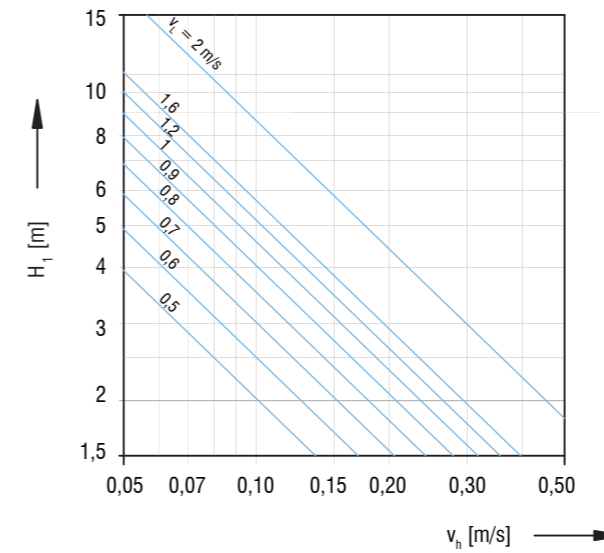

Temperature ratio

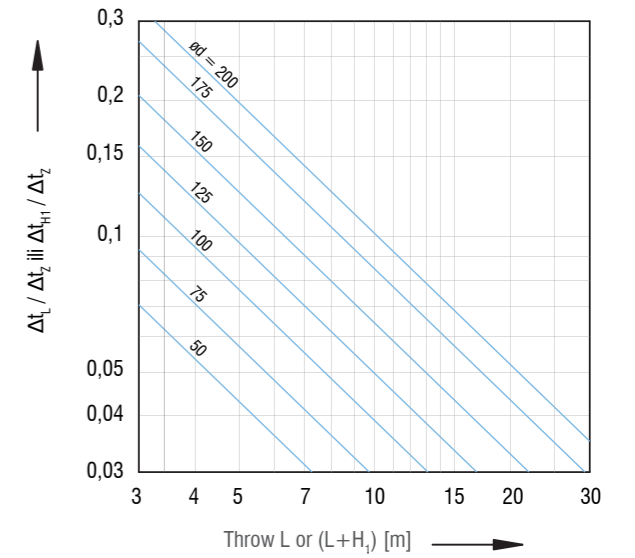

Multiple duct installation SAP-Z

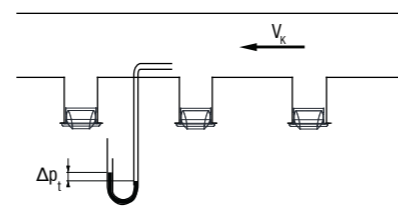
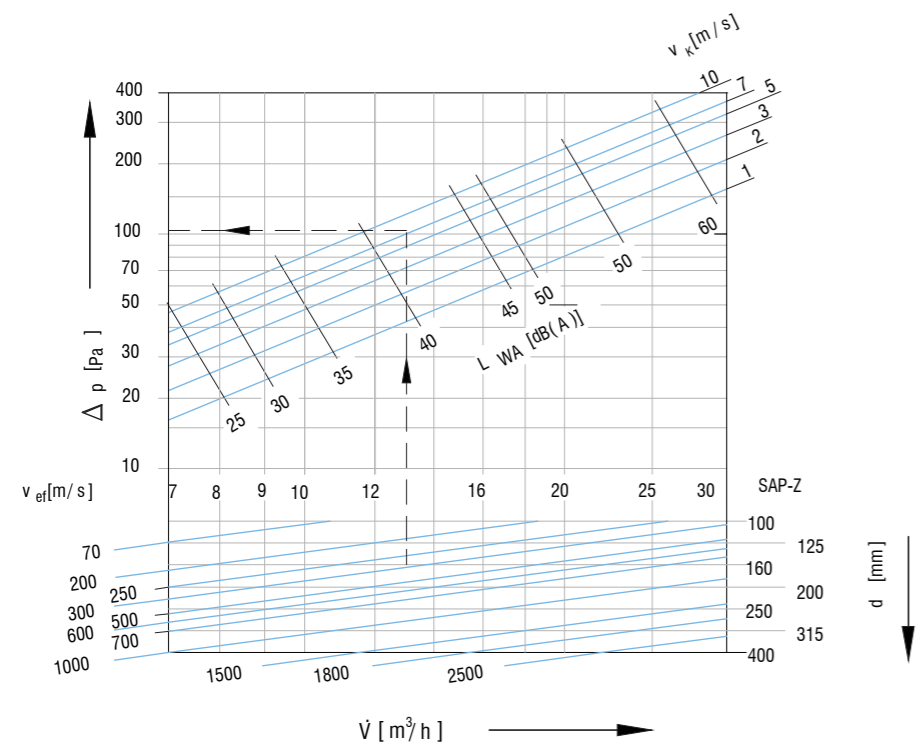

Induction

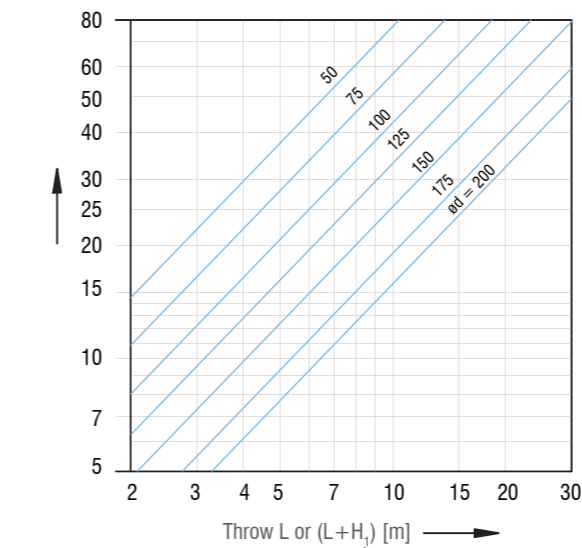

Correction values  $L_{WA}$  [dB(A)]

$\varnothing d$	Discharge angle	
	$\alpha = 0^\circ$	$\alpha = 30^\circ$
50	-6	-5
75	-3	-2
100	-2	0
125	1	2
150	3	4
175	4	6
200	5	7

⚠ For discharge angle  $\pm 30^\circ$  pressure drop is multiplied by a factor of 1,2

